

intreXis[®]

Power Supplies with the X



Datasheet

intreXis USB-C Railway Charger

IC352, 2x15 W Dual-Output

12 Vin – 24 Vin

- ✖ tra two USB-C Sockets for simultaneously charging of latest generation mobile devices.
- ✖ tra full charging current, according to USB Type C and Power Delivery (PD) @ 2x 5 V/ 3 A, ensures short charging time.
- ✖ tra ready for new EU rules valid from 2024. Supporting older devices: Standard BC 1.2 and Apple Divider-Mode 2.
- ✖ tra dedicated for railway passenger compartments and driver desk. Voltage regulation in USB front-end device.
- ✖ tra easy to change USB front-end device in case of vandalism.
- ✖ tra one IC26X DC/DC converter can drive multiple USB front-end devices.

This datasheet covers the details of the IC352 USB-C chargers with dual output voltage and output power of 2x15 W. These DC/DC converters are designed according to EN 50155:2021 and IEC 60571:2012 for railway applications and are ideal for other demanding environments which require the highest performance and reliability.

Output voltage: 5.1 V

Ordering codes: IC352_1, IC352_2, IC352_3, IC352_4.

The differences between the variants are explained in this datasheet.

INPUT CHARACTERISTICS

Continuous Input Voltage Range	<p>10.0 – 25.2 VDC</p> <p>To be powered from DC-DC Converter with regulated output, as example IC273_3, IC248_5, IC263_5 etc. depending on the number of USB chargers connected to the same bus.</p> <p>Not designed to be connected directly to boardnet battery.</p>	
Input Undervoltage Lockout	<p>$V_{in_OFF} = 7.6 \text{ VDC} \pm 2 \%$ $V_{in_ON} = 9.6 \text{ VDC} \pm 2 \%$</p>	
Input Voltage Reverse Polarity Protection	<p>Nosels on connector ensure protection against polarity reversal</p>	
Input Capacitance	<p>20 μF</p>	
Input Current typ. @ full Load	12 Vin	24 Vin
	2.67 A	1.36 A
Input Power typ. @ no Load over the input voltage range	<p>0.11 – 0.15 W</p>	
Internal Input Fuse	<p>No internal fuse is provided</p>	
Startup time (Time input voltage ON to output voltage ON)	<p>< 200 ms for all input voltages</p>	
Wiring	<p>Tested with 25 m (each pole) input wires, 0.5 mm², Vin = 24VDC, 2x15 W-load</p>	

OUTPUT CHARACTERISTICS

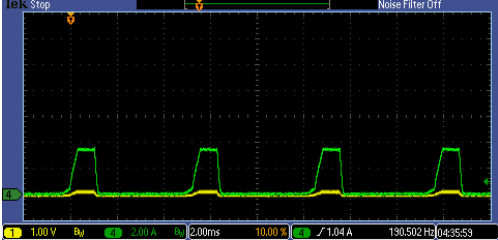
Output Voltage Nominal	2x +5.10 VDC
Max. Continuous Output Power @ $V_{in} = 10.0\text{--}25.2\text{ V}$ (no derating over the entire temperature range)	2x up to 15 W (charging current depends on device to be charged, USB cables, state of the charge)
Minimum Load	No minimum load required
Setpoint Accuracy	< 1.7 %
Load Regulation @ off-load to full load over the entire temperature range	< 2.5 %
Line Regulation @ full load over the entire temperature range	< 0.3 %
Output Ripple & Noise @ 20 MHz bandwidth, including spikes	< 100 mVpp @ -25 – +55 °C
Overload and Short-Circuit	<p>The converter is continuous overload and short-circuit proof.</p> <p>Output overloaded: Up to 3.4 A, constant current. If higher overloads, the converter switches off and retries periodically (hiccup)</p>  <p>CH1 yellow: Output voltage 1 V/Div, CH4 green: Output current 2 A/Div, Timebase: 2 ms/Div</p> <p>Output short-circuited: The converter switches off and tries periodically to switch on again, every 26 ms for 4 ms typ:</p>  <p>CH1 yellow: Output voltage 1 V/Div, CH4 green: Output current 2 A/Div, Timebase: 2 ms/Div</p> <p>If the short-circuit is removed, the converter switches on at the next switch-on attempt (hiccup).</p>
Current Limit, each output (varies due to component tolerances)	3.16 – 3.64 A
Short-Circuit current	< 2.0 Arms

EFFICIENCY

Conditions	12 Vin	24 Vin
Efficiency typ. @ 100 % Load	93.6 %	92.0 %
Efficiency typ. @ 66 % Load	94.8 %	93.0 %
Efficiency typ. @ 33 % Load	95.0 %	92.0 %

SIGNALS AND INTERFACES

The IC352_X charger handles the signals necessary to detect the attached device and enable the charging at full current. It implements the following protocols over USB Type-C connectors:

- USB Type-C Rev. 1.2 and Power Delivery (PD) @ 2x 5V / up to 3 A (charging current depends on device to be charged, USB cables, state of the charge)
- Supports USB Dedicated Charging Port for backward compatibility (according to Battery Charging standard BC 1.2 and Divider Mode 2)

Tested with Apple, Samsung, Huawei, Honor.

ELECTROMAGNETIC COMPATIBILITY (EMC)

Test	Standard	Test severity levels	Performance Criteria
Electrostatic discharge	EN 50155:2021 EN 50121-3-2:2016/ A1:2019 IEC60571:2012 IEC 62236-3-2:2018	±6 kV contact discharge ±8 kV air discharge	Criterion B required, but compliant with more strict criterion A
Fast transients	EN 50155:2021 EN 50121-3-2:2016/ A1:2019 IEC60571:2012 IEC 62236-3-2:2018	±2 kV 5/50 ns tr/th 5 kHz repetition frequency	Criterion A
Radio-frequency common mode	EN 50155:2021 EN 50121-3-2:2016/ A1:2019 IEC60571:2012 IEC 62236-3-2:2018	150 kHz – 80 MHz 10 Vrms (carrier voltage) 80 % AM, 1 kHz Source impedance 150 Ω	Criterion A
Radio-frequency electromagnetic field	EN 50155:2021 EN 50121-3-2:2016/ A1:2019 IEC60571:2012 IEC 62236-3-2:2018	80 MHz – 1000 MHz 20 Vrms/m 80 % AM, 1 kHz unmodulated carrier; 1400 MHz – 2000 MHz 10 Vrms/m 80 % AM, 1 kHz unmodulated carrier; 2000 MHz – 2700 MHz 5 Vrms/m 80 % AM, 1 kHz unmodulated carrier; 5100 MHz – 6000 MHz 3 Vrms/m 80 % AM, 1 kHz unmodulated carrier	Criterion A
Conducted emissions	EN 50155:2021 EN 50121-3-2:2016/ A1:2019 IEC60571:2012 IEC 62236-3-2:2018	150 kHz – 500 kHz: 99 dBµV quasi-peak 500 kHz – 30 MHz: 93 dBµV quasi-peak	
Radiated emissions	EN 50155:2021 EN 50121-3-2:2016/ A1:2019 IEC60571:2012 IEC 62236-3-2:2018	30 MHz – 230 MHz: 40 dBµV/m quasi-peak at 10 m 230 MHz – 1000 MHz: 47 dBµV/m quasi-peak at 10 m	

ENVIRONMENTAL CHARACTERISTICS

Operating Temperature	-25 °C – +70 °C Class OT1: -25 – +55 °C and class ST1,ST2: +15 °C according to EN 50155:2021
Cooling	Natural convection
Storage Temperature Range	-50 °C – +100 °C
Altitude Class	Class Ax (>1400 m) according to EN 50125-1:2014: 5000 m above sea level max.
Pollution Degree	PD2 according to EN 50124-1:2017
Shock and Vibration	According to EN 61373:2010, category 1, class B
Rapid Temperature Variation	Class H2 according to EN 50155:2021: -25 °C to +15 °C / 95 %RH, ±3 K/s +10 °C to +40 °C / 60 %RH, ±3 K/s
Protective Coating	Class PC2 according to EN 50155:2021 The board is protected on both sides with a protective transparent fluorescent-pigment coating to prevent deterioration or damage due to moisture and atmospheric contaminants. The coating is compliant with class 2, according to IPC-A-610H
Prohibited Substances	No substances defined as Prohibited according to the RoHS, REACH, UNIFE (RISL), or Prohibited for the Project, are present. No substances defined as Declarable according to RoHS, REACH, UNIFE (RISL), or Declarable for the Project, are present.
Fire behaviour	EN 45545-2:2020 compliant with all Hazard Levels HL1-HL3

GENERAL CHARACTERISTICS

General Standard	EN 50155:2021 Railway applications - Rolling stock - Electronic equipment IEC 60571:2012 Railway applications - Electronic equipment used on rolling stock			
Useful Life Class	Class L4 (20 years) according to EN 50155:2021			
MTBF Calculation method: MIL-HDBK-217-F2 Using demonstrated Failure Rates of components	Ground Benign (GB), +25 °C	Ground Benign (GB), +40 °C	Ground Fixed (GF), +40 °C	Ground Mobile (GM), +40 °C
	52 336 000 h	34 415 000 h	6 909 000 h	3 751 000 h
MTBF Calculation method: SN 29500 (IEC 61709)	5 604 000 h @ +40 °C			
Marking	Label with following information: - part number, output voltage, output power - unique serial number for identification and traceability (printed in text format and as barcode) - revision index			
Connector identification	Printings on PCB to identify input connector and pin-number.			

SAFETY AND INSULATION

Safety Standards	EN 60950-1:2006+A2:2013, IEC 60950-1:2005+A1:2009+A2:2013 CSV, EN 62368-1:2014+A11:2017 IEC 62368-1:2018
Insulation Coordination	According to EN 50124-1:2017
Input to Output	The input is not galvanically isolated to the output.
Output to Chassis	Not applicable

BLOCK DIAGRAM

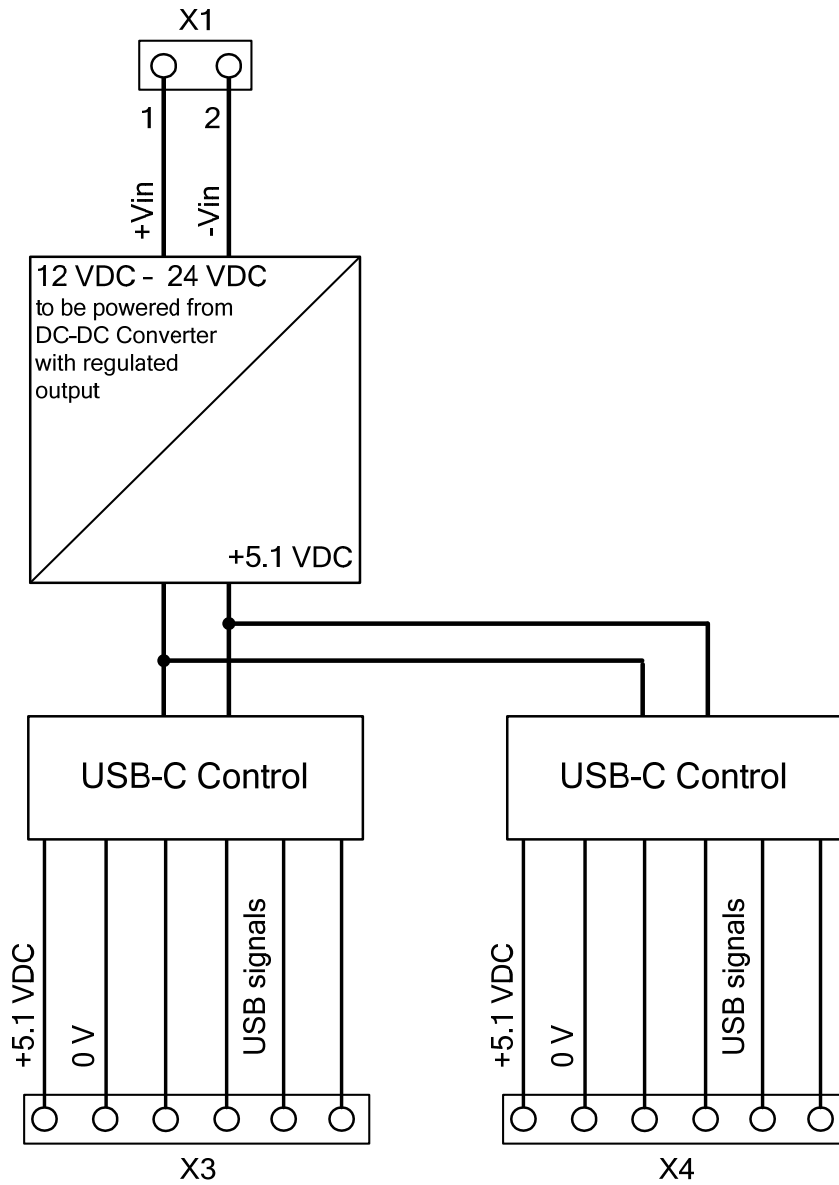

CONNECTOR TYPES

IC352_1, IC352_3, IC352_4 (horizontal input-connector on top)

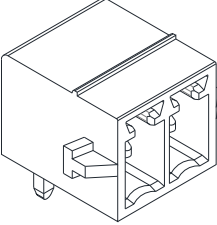
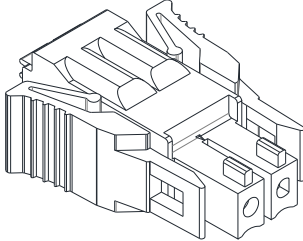
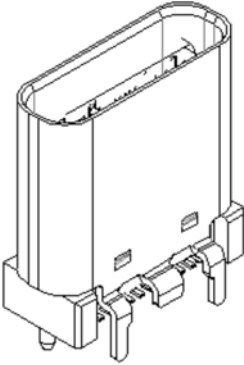
<p>Input connector X1</p>	<p>Phoenix MC 1,5/ 2-G-3,5-RN or equivalent Pitch: 3.5 mm Number of pins: 2</p>  <p>Mating part: Phoenix FMC 1,5/ 2-ST-3,5-RF, Ordering code: 1952021</p> 
<p>Output connectors X3,X4</p>	<p>GCT USB4115-03 Pitch: according to USB C Number of pins: 24 Durability: 10 000 cycles min. of insertion/extraction</p>  <p>Mating part: USB C plugs</p>

IC352_2 (vertical input-connector on bottom)

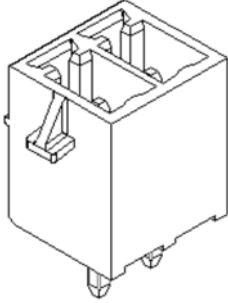
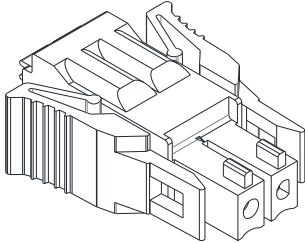
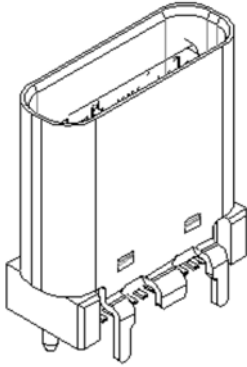
<p>Input connector X1</p>	<p>Phoenix MCV 1,5/ 2-G-3,5-RN or equivalent Pitch: 3.5 mm Number of pins: 2</p>  <p>Mating part: Phoenix FMC 1,5/ 2-ST-3,5-RF, Ordering code: 1952021</p> 
<p>Output connectors X3,X4</p>	<p>GCT USB4115-03 Pitch: according to USB C Number of pins: 24 Durability: 10 000 cycles min. of insertion/extraction</p>  <p>Mating part: USB C plugs</p>

MECHANICAL CHARACTERISTICS

Front-plate	<p>IC352_1: Stainless Steel</p> <p>IC352_2: not implemented (only PCB)</p> <p>IC352_3, IC352_4: Aluminium: EN AW 5052 - AL5052 - AlMg2.5 or EN AW 5754 - AL5754 - AlMg3 Black anodized</p>
Overall dimensions	According to the drawing (millimetres, unless otherwise specified)
Weight	<p>IC352_1: 100 g</p> <p>IC352_2: 16 g</p> <p>IC352_3: 38 g</p> <p>IC352_4: 34 g</p>
IP code	<p>IP00 in general</p> <p>IP30 on front panel</p>
Mounting	Mounting in any position is allowed

Mechanical drawings:
IC352_1:

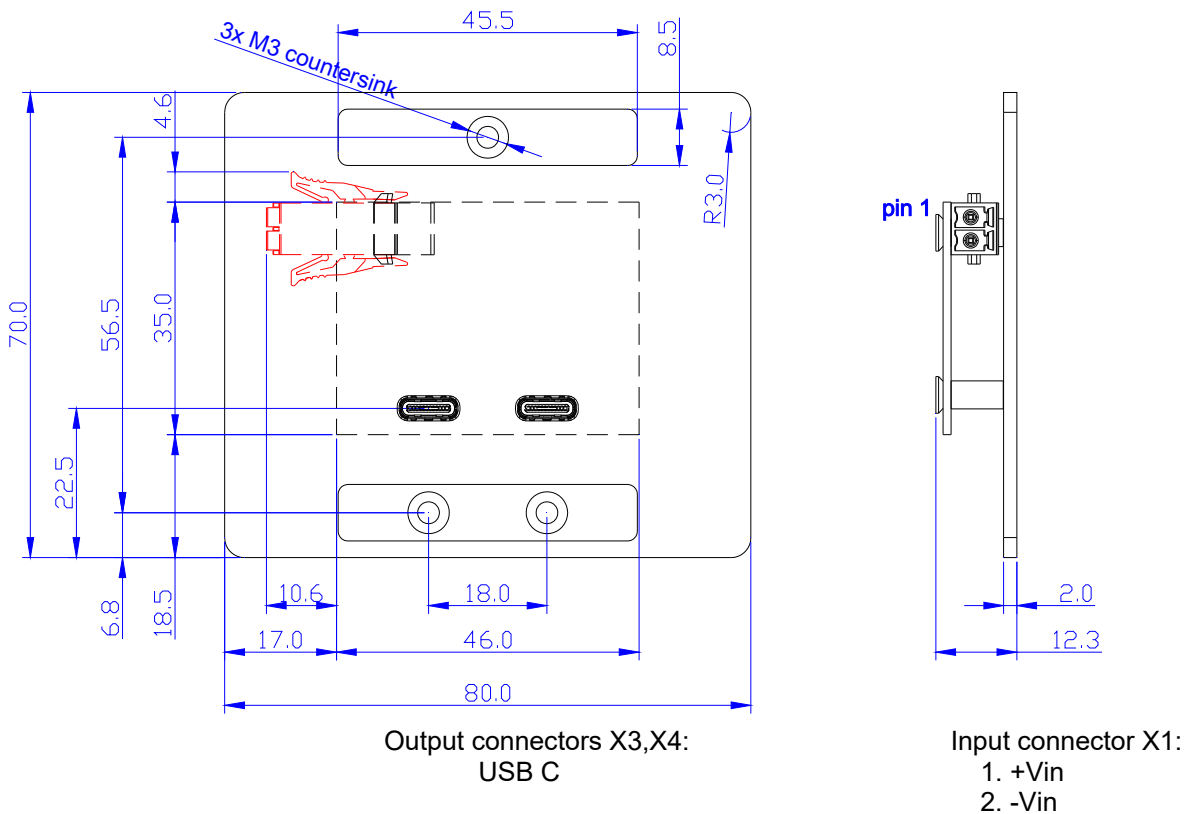

Parts colored in red are mating connectors, that are not provided and are shown for illustration

The unit must be secured using three M3 screws, flat-head (not supplied) in the mounting holes.

IC352_2:

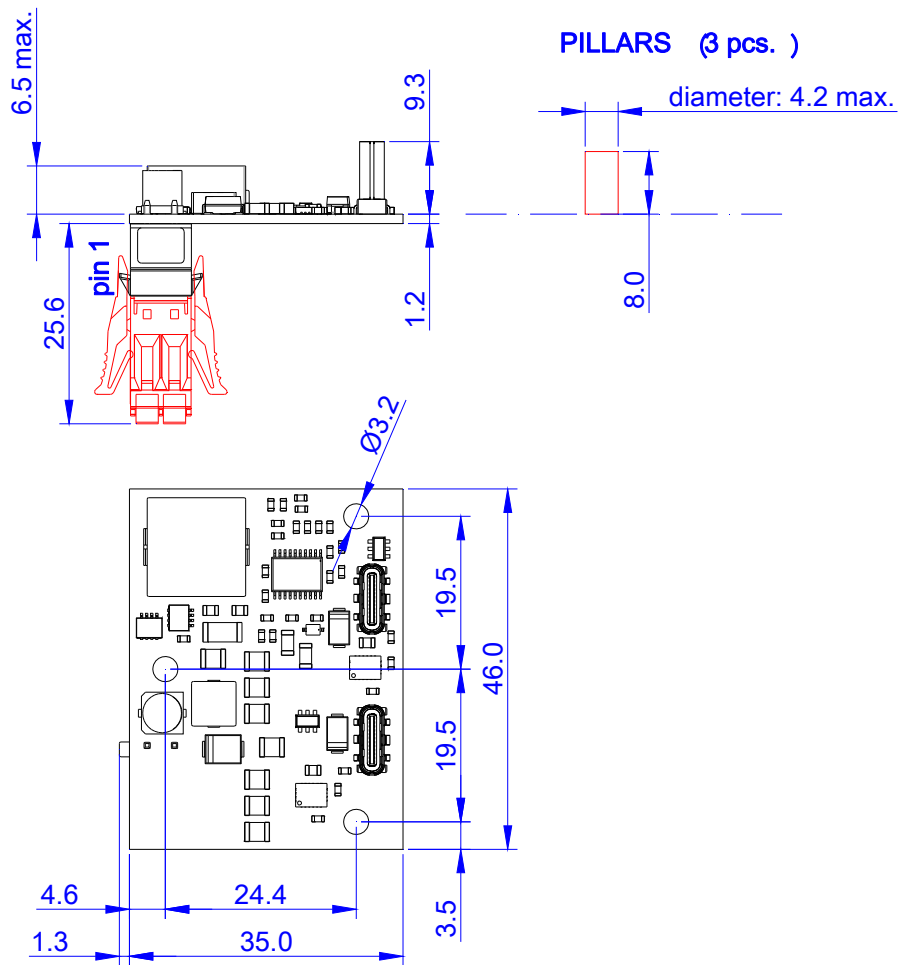

Parts colored in red are mating connectors, that are not provided and are shown for illustration

The unit must be mounted onto a front-plate (recommended thickness: 2.0 mm). Mounting pillars (not provided) must ensure a distance from PCB to front-plate of 8.0 mm. The max. diameter of the pillars is 4.2 mm, otherwise electrical creepage is violated. Three screws M3x6 mm (not provided) have to be assembled to fix the PCB onto the pillars. If metallic screws are used, they must be flat-head type, otherwise electrical creepage is violated.

IC352_3:

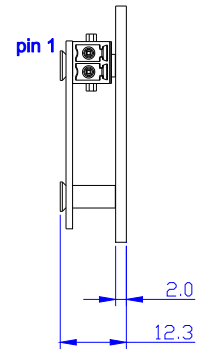
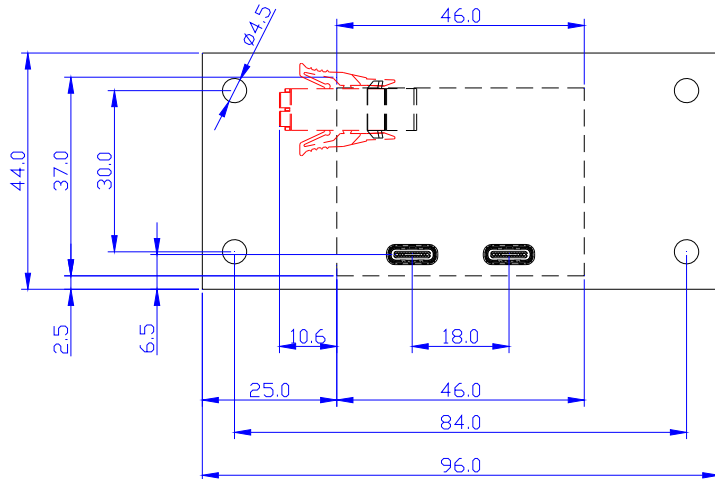

Output connectors X3,X4:
USB C

Input connector X1:
1. +Vin
2. -Vin

Parts colored in red are mating connectors, that are not provided and are shown for illustration

The unit must be secured using four M4 screws or bolts (not supplied) in the mounting holes.

IC352_4:

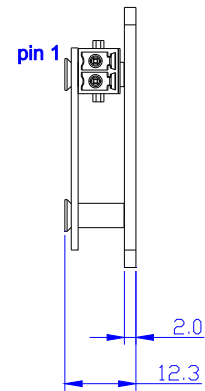
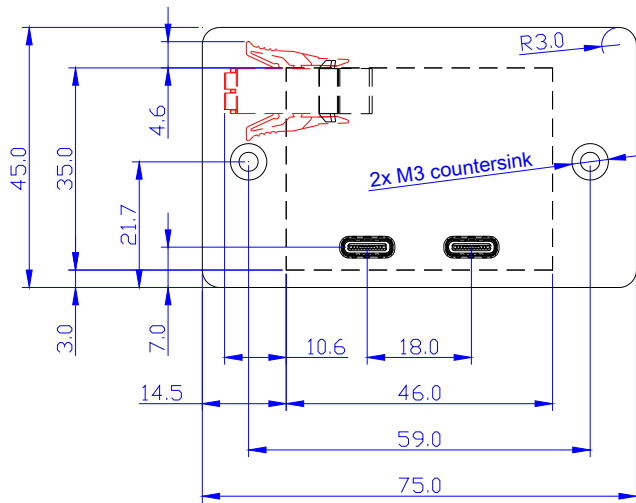

Output connectors X3,X4:
USB C

Input connector X1:
1. +Vin
2. -Vin

Parts colored in red are mating connectors, that are not provided and are shown for illustration

The unit must be secured using two M3 screws, flat-head (not supplied) in the mounting holes.

TEST COMPLIANCE SUMMARY (CERTIFICATE OF CONFORMITY)

Performed Test	Standard	Test conditions	Performance level	Reference document
Visual inspection	EN 50155:2021 IEC60571:2012	Aspect, dimensions, weight, markings	According to design specification	Test report
Performance test	EN 50155:2021 IEC60571:2012	Ambient temperature. Nominal supply voltage: 12 VDC and 24 VDC Supply voltage range: 10.0 – 25.2 VDC (static)	Criterion A	Test report
DC Power supply test Supply overvoltages	EN 50155:2021 IEC60571:2012	Supply voltage: 10.0 – 25.2 VDC	Criterion B required, but tested with more strict criterion A	Test report
Low temperature test	EN 50155:2021 IEC60571:2012	T = -25 °C	Criterion A	Test report
Dry heat test	EN 50155:2021 IEC60571:2012	T = +55 °C (cycle A)	Criterion A	Test report
Low temperature storage test	EN 50155:2021 IEC60571:2012	T = -50 °C	Criterion A after recovery period	Test report
Insulation test	EN 50155:2021 IEC60571:2012	Not applicable	Resistance > 20 MΩ (measured >550 MΩ, exceeding the requirement) No disruptive discharge	
Cyclic damp heat test	EN 50155:2021 IEC60571:2012	T = +55 °C and +25 °C (2 cycles)	Criterion A	Test report
Electromagnetic compatibility test	EN 50155:2021 EN 50121-3-2:2016/ A1:2019 IEC60571:2012 IEC 62236-3-2:2018	See section 'Electromagnetic Compatibility (EMC)'		TestreportEMC_ R-EM-354-0222-02A
Shock and vibration test	EN 50155:2021 IEC60571:2012	EN 61373:2010, Category 1, class B		Compliant

Additional tests:

Performed Test	Standard	Test conditions	Performance level	Reference document
Fire behaviour	EN 45545-2:2020	PCB: R25 (EN 60695-2-11, T16: No ignition at T=850 °C)	PASSED (HL1-HL2-HL3)	Fire_Certificate_IC352

Furthermore, the product is compliant with the requirements of:

- EC 1907/2006 (December, 18th 2006) REACH regulation: Registration, Evaluation, Authorisation and Restriction of Chemicals.
- UNIFE Railway Industry Substance List

Neuhausen am Rheinfall, 31.01.2022

Thomas Schiegg
intreXis AG







EU DECLARATION OF CONFORMITY (DoC)

Product Models	IC352_1, IC352_2, IC352_3, IC352_4		
Name and address of the manufacturer	intreXis AG Tobelraastrasse 4 CH-8212 Neuhausen am Rheinfall Switzerland		
This declaration of conformity is issued under the sole responsibility of the manufacturer.			
IC352_1 	IC352_2 	IC352_3 	IC352_4 
The object of the declaration described above is in conformity with the relevant Union harmonisation legislation:	Low Voltage Directive: RoHS Directive: EMC Directive:	2014/35/EU 2011/65/EU, (EU) 2015/863 2014/30/EU	
References to the relevant harmonised standards used or references to the other technical specifications in relation to which conformity is declared:	Low Voltage Directive: RoHS Directive: EMC Directive: Railway Applications:	EN 62368-1:2020/A11:2020 EN 63000:2018 EN 50121-3-2:2016/ A1:2019 EN 50155:2021	
Signed for and on behalf of:	intreXis AG Tobelraastrasse 4 CH-8212 Neuhausen am Rheinfall Switzerland		
Place, Date of issue	Neuhausen am Rheinfall, 31.01.2022		
Name, Function, Signature	Thomas Schiegg, Managing Director: 		



UK DECLARATION OF CONFORMITY (DoC)

Product Models	IC352_1, IC352_2, IC352_3, IC352_4		
Name and address of the manufacturer	intreXis AG Tobelraastrasse 4 CH-8212 Neuhausen am Rheinfall Switzerland		
This declaration of conformity is issued under the sole responsibility of the manufacturer.			
IC352_1	IC352_2	IC352_3	IC352_4
			
The object of the declaration described above is in conformity with the relevant UK legislation:	UK SI 2016 No. 1101:	Electrical Equipment (Safety) Regulations 2016	
	UK SI 2012 No. 3032:	The Restriction of the Use of Certain Hazardous Substances in Electrical and Electronic Equipment Regulations 2012	
	UK SI 2016 No. 1091:	Electromagnetic Compatibility Regulations 2016	
References to the relevant standards used or references to the other technical specifications in relation to which conformity is declared:	Low Voltage Directive:	BS EN 62368-1:2020/A11:2020	
	RoHS Directive:	BS EN IEC 63000:2018	
	EMC Directive:	BS EN 50121-3-2:2016/A1:2019	
	Railway Applications:	BS EN 50155:2021	
Signed for and on behalf of:	intreXis AG Tobelraastrasse 4 CH-8212 Neuhausen am Rheinfall Switzerland		
Place, Date of issue	Neuhausen am Rheinfall, 31.01.2022		
Name, Function, Signature	Thomas Schiegg, Managing Director: 		

INSTALLATION AND OPERATION

<p>Safety</p>	<div style="display: flex; align-items: center;">  <div> <p>Warning / Caution!</p> <p>The power supplies should be installed and put into operation only by qualified personnel.</p> </div> </div> <p>Before installing or removing the unit, disconnect the power from the system.</p>
<p>Servicing</p>	<p>In case of failures, malfunctions or defects, the converter must be returned to intreXis for analysis and repair. In particular, the converter should be sent to intreXis for analysis if any damage has occurred to the unit (e.g. the unit dropped). Any attempts to open and repair the unit could void the warranty and could expose the operator to hazardous voltages.</p>
<p>Spare Parts</p>	<p>List and drawings of spare parts are not provided, since the failed units have to be returned to intreXis for analysis and repair.</p>
<p>Disposal</p>	<p>Disused units must be collected separately and disposed at a suitable recycling facility.</p>
<p>Connecting the Cables</p>	<p>Ensure that proper wires are used according to the input current specifications. Prepare the cables according to the specifications of the particular connector used.</p>
<p>Operation of the Unit</p>	<p>Once the input power is applied, the output voltage is ready. Once a device is attached to an USB connector, the output voltage at the connector is enabled and charging starts.</p>